

Document Title: <b>Upper (Superstructure), removal</b>	Function Group: <b>frame 710</b>	Information Type: <b>Service Information</b>	Date: <b>2014/11/17</b>
Profile:			

## Upper frame (Superstructure), removal

### **WARNING**

The superstructure weigh approximate 4 ~ 7 tons (excluding counterweight and digging units). Pay attention to safe footing and the area around the crane before proceeding to remove or install the superstructure.

1. Remove the digging unit.
2. Disconnect turning joint clamping screw, seal cover, hydraulic oil hoses, drain hose, and one servo hydraulic oil hose from turning joint.

**NOTE!**

Bundle the hoses. Blind plug each disconnected hose and pipe.

3. Remove screws (A) fixing the outer race of the slew ring.

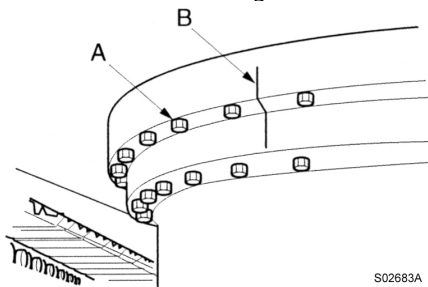

**Figure 1**  
**Slew ring installed**

- A. Screw
- B. Confirm alignment of match marks

4. Dismantle the cab, counterweight and guard. Place a wire rope on the upper frame and lift it with a crane to an extent that the wire rope is not slack.

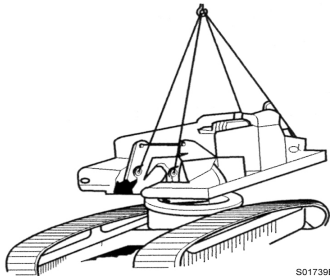

**Figure 2**  
**Lifting the upper frame**

5. Lift the upper frame just a little, and after confirming safety all around, lift it up and out.

Document Title: <b>Upper (Superstructure), installation</b>	<b>frame</b>	Function Group: <b>710</b>	Information Type: <b>Service Information</b>	Date: <b>2014/11/17</b>
Profile:				

## Upper frame (Superstructure), installation

1. Bundle the hoses attached to the turning joint together and place them upright.
2. Coat the screws and threaded holes of the slew ring with "Three bond 1215" (Loctite #515).

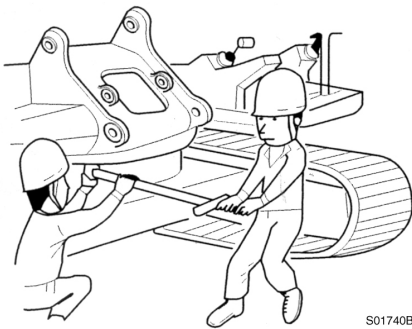

**Figure 1**  
**Installing the upper frame**

3. Lift the upper frame and install it to the slew ring.

**NOTE!**

Lower the superstructure so that the slew pinion and the slew ring are engaged.

**NOTE!**

For tightening torque, see torque chart.

**NOTE!**

Tighten diagonally opposite screws in sequence.

4. Connect the hoses, turning joint clamping screw and seal cover disconnected for removal.

Document Title: <b>Additional counterweight &amp; digging unit</b>	Function Group: <b>716</b>	Information Type: <b>Service Information</b>	Date: <b>2014/11/17</b>
Profile:			

## **Additional counterweight & digging unit**

When special digging units (such as : scrap handling clam, log loader etc.,) are installed on the excavators, an additional counterweight is required for stability.

In these cases, check the digging unit specification and compare it carefully to the excavator load lifting capacity chart.

And if in doubt, contact your local dealer for advice.

Additional counterweight can be installed according to special digging units, however we are not responsible for any failure of the excavator or breakage of digging units due to such application.

For reference, an excavator is basically designed only for excavating and is not designed to be used as a crane.

Document Title: <b>Undercarriage, description</b>	Function Group: <b>7181</b>	Information Type: <b>Service Information</b>	Date: <b>2014/11/17</b>
Profile:			

## Undercarriage, description

Undercarriage consists of idlers, springs, top and bottom rollers, sprockets, track links, track frame and track guards.

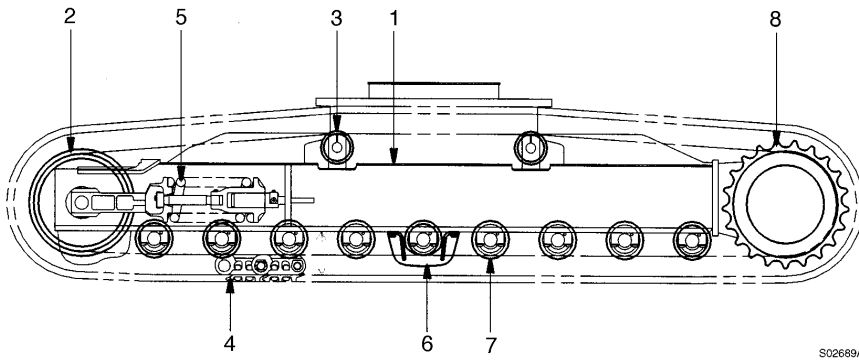

**Figure 1**  
**Structure, undercarriage**

1	Track frame	5	Spring package
2	Idler	6	Track guard
3	Top roller	7	Bottom roller
4	Track link	8	Sprocket

**Hello**

**Thank you very much  
for reading.**

**PLEASE CLICK HERE.**

Then back to the site.

At the bottom of the  
page,

free add to card.

**Then get more free information**