

Housing (Front) - Install

SMCS - 1151-012

Installation Procedure

Table 1

Tool	Part Number	Part Name	Qty
A	-	Guide Bolt (M8 X 1.25 by 70 mm)	2
B	5P-3975	Rubber Lubricant	-

NOTICE

Keep all parts clean from contaminants.

Contaminants may cause rapid wear and shortened component life.

1. Clean all mating surfaces thoroughly.
-

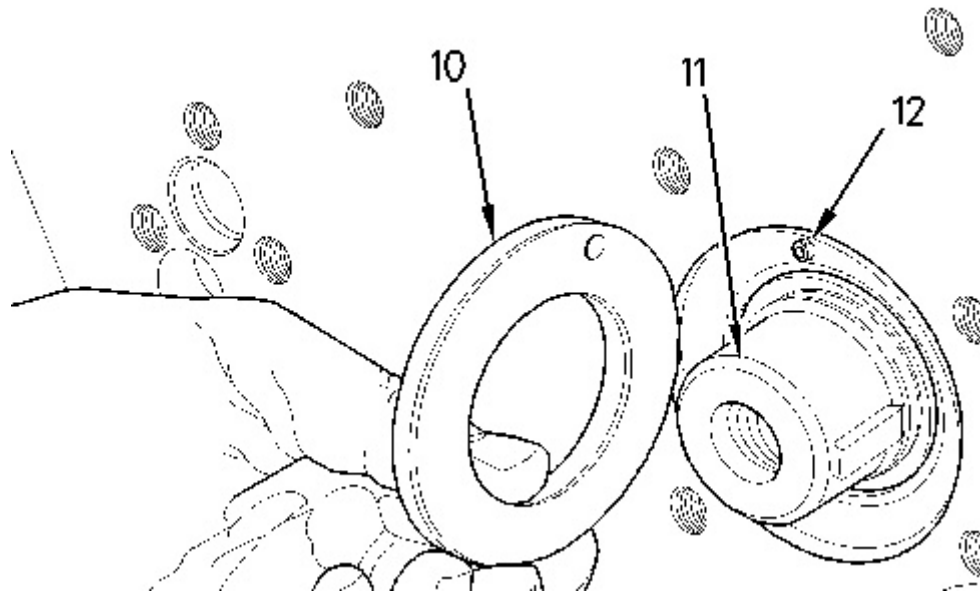

Illustration 1

g00954818

2. Ensure that thrust washer (10) is aligned with hollow dowel (12). Install the thrust washer on camshaft (11).
3. Install a new O-ring seal on the fuel injection pump housing.

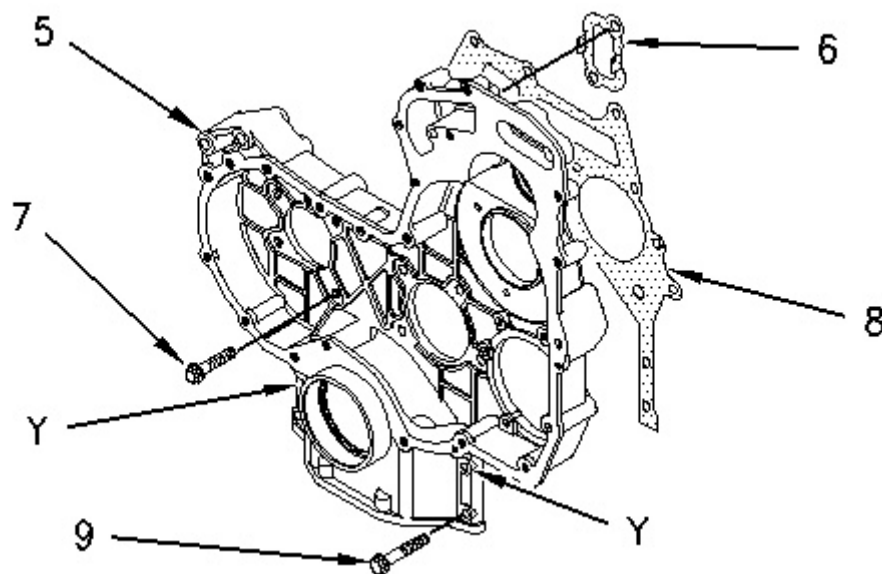

Illustration 2

g00995387

4. Install Tooling (A) in the cylinder block in Hole (Y).
5. Position gasket (8) on Tooling (A). Install gasket (6) on the back side of front housing (5).
6. Position front housing (5) on the cylinder block. Install bolts (7) and bolts (9). Remove Tooling (A) and install the remaining bolts in order to secure the front housing to the cylinder block. Tighten bolts (7) and bolts (9) finger tight at this time.

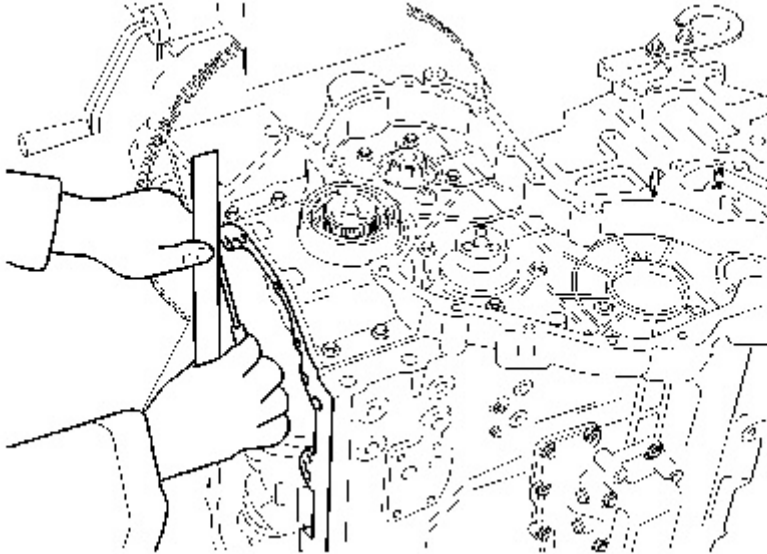

Illustration 3

g00954906

7. Align the front housing and the cylinder block.

Note: Ensure that the bottom of the front cover is aligned with the bottom of the cylinder block before the bolts are tightened. The alignment of the bottom face of the front cover and the bottom of the cylinder block must not exceed 0.00 ± 0.05 mm (0.000 ± 0.002 inch).

8. Tighten bolts (7) and bolts (9) to a torque of 22 N·m (16 lb ft).

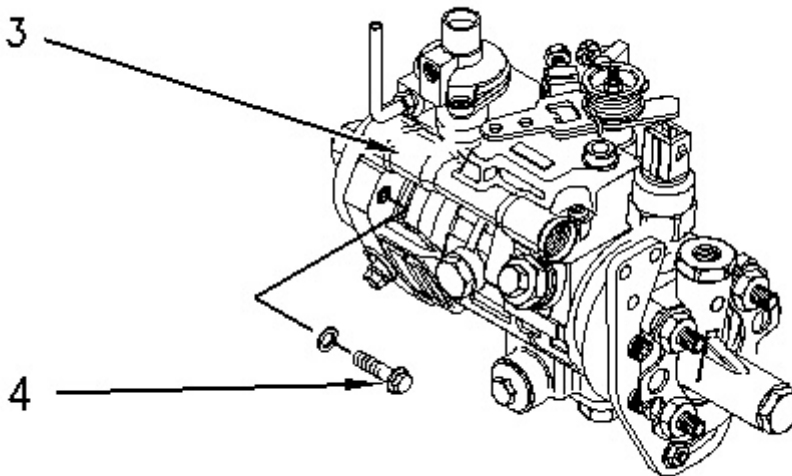

Illustration 4

g00994883

Typical Example

9. Install bolts (4) that fasten fuel injection pump (3) to the front housing. Tighten the bolts to a torque of 25 N·m (18 lb ft).

Thank you very much for your reading. Please Click Here. Then Get COMPLETE MANUAL. NO WAITING



NOTE:

If there is no response to click on the link above, please download the PDF document first and then click on it.

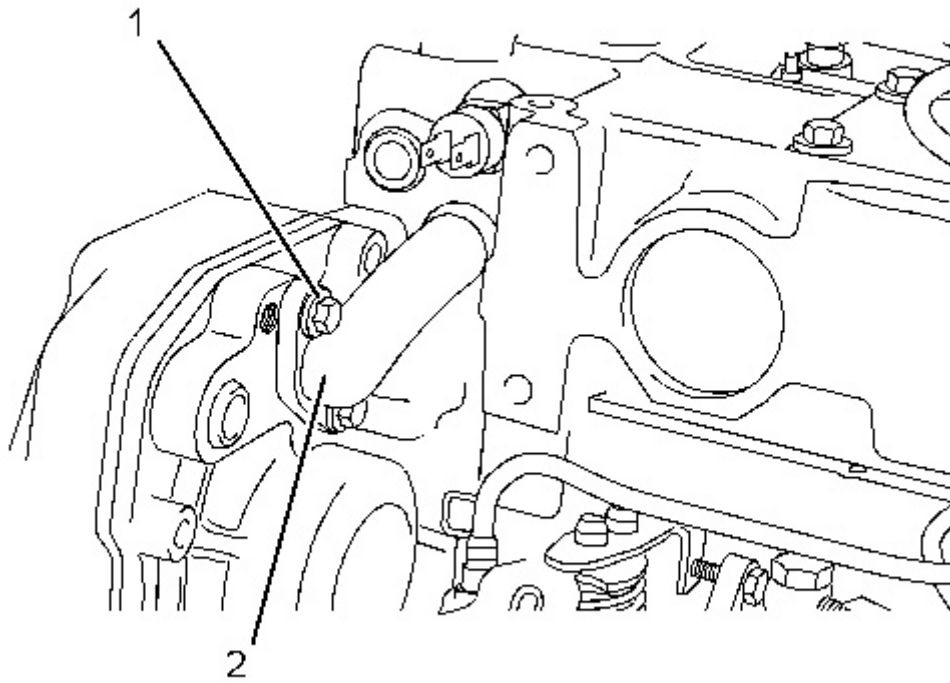

Illustration 5
Typical example

g03373179

10. Install new O-ring seals on bypass tube (2). Apply Tooling (B) to the O-ring seals. Install the bypass tube in the cylinder head. Install bolts (1).

End By:

- a. Install the camshaft gear. Refer to Disassembly and Assembly, "Camshaft Gear - Remove and Install".
- b. Install the idler gear. Refer to Disassembly and Assembly, "Idler Gear - Remove and Install".
- c. Install the engine oil pan. Refer to Disassembly and Assembly, "Engine Oil Pan - Remove and Install".
- d. Install the front cover. Refer to Disassembly and Assembly, "Front Cover - Remove and Install".
- e. Install the crankshaft pulley. Refer to Disassembly and Assembly, "Crankshaft Pulley - Remove and Install".
- f. Install the alternator. Refer to Disassembly and Assembly, "Alternator - Install".
- g. Install the air compressor, if equipped. Refer to Disassembly and Assembly, "Air Compressor - Remove and Install".